

**1. Intended use / product description**

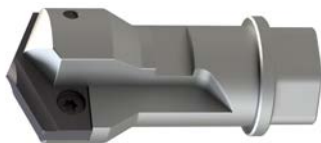

**Material:** Cutting insert made of carbide

The carbide indexable insert drill is a drilling tool suitable for drilling cast iron pipes with cement coating inside and outside. The use of a rotary drive is required. The drilling process must be carried out with a slow and even feed. The operating instructions for the Hawle drilling device Hawlomat Ord. No. 830-00 must be observed. Moreover, drills of sizes Ø31mm and Ø36mm are provided with an outer hexagon for fixing the drill bit at the drill rod by means of a locking sleeve.

drill rotation speed drilling tool: 20-60 rpm





The applicable standards and regulations, accident prevention regulations, as well as the trade associations' provisions regarding the drilling process shall be observed and complied with. Drilling should be performed by skilled personnel only.

**2. Installation**

	Torx® wrench T09, T15, T20
--	----------------------------

Before drilling, the drilling saddle should be filled with water, if possible, to ensure cooling and thus help to increase the service life of the drill bits.



Before using the drill bit, the drill insert must be checked for damage and replaced, if necessary. Defective drill inserts can be exchanged by removing the fixing screws.

<p>1. Remove the fixing screw</p> 	<p>2. Take out the drill insert</p> 
<p>3. Clean the seat of the drill insert</p> 	<p>4. Install new drill insert and fasten with enclosed fixing screws ( observe the tightening torque )</p> 

## Tightening torque of fixing screws

Drill bit Ø 24mm	Torx® profile T09	3 Nm
Drill bit Ø 31mm	Torx® profile T15	5 Nm
Drill bit Ø 36mm	Torx® profile T20	6 Nm

## Fixing at drill rod by means of locking sleeve

<p>1. Unscrew the drill bit until it is approx. ¼ turn away from the stop while aligning the outer hexagon surfaces of the drill rod and drill bit in parallel to each other.</p>	<p>2. For unlocking the retaining sleeve, actuate the plastic ring at the oval spot and secure the drill bit against rotation by pushing the retaining sleeve onto the hexagon of the drill bit.</p> <p><b>Important:</b> The markings on the sleeve and on the hexagon of the drill rod indicate the alignment of the sleeve. After successfully positioning the sleeve, the plastic ring of the sleeve engages in the notch of the drill rod, thus fixing the sleeve.</p>
	

After use, make sure to remove any swarf deposited on the drill bit.

### 3. Servicing and maintenance

Hawle carbide indexable insert drills do not require any maintenance. Defective components have to be exchanged as needed.

**If you have any other questions or if you need more information please contact:**

Hawle Armaturen GmbH  
- Application Engineering -  
Liegnitzer Str. 6  
83395 Freilassing  
Telephone: +49 (0)8654 6303-0  
Telefax: +49 (0)8654 6303-222  
E-Mail: [info@hawle.de](mailto:info@hawle.de)  
Internet: [www.hawle.de](http://www.hawle.de)